

Intelligent Control Based Fuzzy Logic for Automation of Greenhouse Irrigation System and Evaluation in Relation to Conventional Systems

P. Javadi Kia, A. Tabatabaee Far, M. Omid, R. Alimardani and L. Naderloo

Department of Agricultural Machinery Engineering, University of Tehran, Karaj, Iran

Abstract: The idea of irrigation is not new, irrigation stems as far back as the Egyptians and probably further in unrecorded history. Even the idea of automated irrigation is not new, mankind has figured out how to irrigate large areas of foliage through the use of automated and drop irrigation systems. Efficient, automated irrigation systems, which can irrigate plants to a desired level and supply those plants with just the amount of water required for normal an uptake plant growth, are currently not available. These systems, if developed, could reduce waste of irrigated water. The irrigation controller is the "brain" of an entire irrigation system. It supervises the flow of water and fertilizer to the plants, therefore, enables the farmer, or the gardener, to obtain optimized results: A successful crop or a beautiful garden, by using an optimum amount of water and fertilizer. Nowadays computerized control is very essential for the greenhouse irrigation control. Many conventional methods for controlling greenhouse irrigation are not effective since they are either based on on-off control methods or proportional control methods. This results in a loss of energy and productivity. The paper presents a solution for an irrigation controller based on the fuzzy-logic methodology. First, it describes the general problem of irrigation. Then, it discusses the physical control model. The developed Fuzzy Logic Controller (FLC) prototype is based on a Mamedani controller and it is built on MATLAB software. Following the discussion and the formal presentation of the fuzzy controller, the paper provide examples that will show the simplicity in designing and constructing such a system and other advantages of using fuzzy logic in the feedback control problem. The developed fuzzy logic controller can effectively estimate amount of water uptake of plants in distinct depth using the reliable irrigation model, evapotranspiration functions, environmental conditions of greenhouse, soil type, type of plant and another factors affecting the irrigation of greenhouse.

Key words: Control . Fuzzy . Automation . Greenhouse . Irrigation system

INTRODUCTION

Water is a basic component of all known life on Earth. Water can both sustain life in correct quantities and threaten life when it is not available or overabundant. Water as a result is a very precious natural resource that must not be wasted. If too much water is applied the problems arise consisting of runoff, erosion, waste of water and deceased plant life. If too little water is applied different problems arise such as turf burnout. The key in irrigation is striking to correct balance for optimal plant life with optimal use of water [1, 2].

Irrigation controllers are divided roughly into two main classes [3].

Open loop controllers: These are based on a pre-defined control concept, with no feedback from the controlled object. Most (if not all) of the simple

controllers operate in this fashion. The user sets the time to start, the time to end, the pause intervals and the watering periods. These parameters are preset for the entire session. That is:

- How long the irrigation session should last,
- How often the irrigation period should repeat itself and
- How much water (and/or fertilizer) will be used in these irrigation sessions.

No checking is done to know whether the right amount of water is used or not. These types of controllers, though relatively cheap, are not very good, since in most cases they do not provide the optimal (or even a good) solution to the irrigation problem. The major factor in the irrigation process is the time. Therefore, the open-loop controller uses a periodic irrigation policy [4]. In this policy, the irrigation is

based on the relevant amounts of water that must be given periodically (a large amount once in few days, or fractions on each day). The experts claim that periodic irrigation with large amounts is better because it washes the soil free of chemicals and creates a better balanced soil chemically [5].

Closed-loop controllers: These are based on a combination of pre-defined control concept (feed-forward) and feedback from the controlled object. In this type of controller, there is a feedback of the necessary data to determine the amount of water needed for irrigation. There are several parameters that should influence the decision of how much water to use in the irrigation process. Some of these parameters are fixed for the session and are of an agricultural nature (such as the kind of plants, kind of soil, leaf coverage, stage of growth, etc.) and some of them vary and should be measured during the irrigation process. These parameters are of a physical nature (such as temperature, air humidity, radiation in the ground, soil humidity, etc.). So when these conditions change, the amount of water being used for the irrigation should change also [6].

The system described in this paper utilizes *closed-loop control*. The controller receives feedback from one or more sensors in the field, that continuously provide updated data to the controller about parameters that are influenced by the system behavior (such as soil moisture level, temperature in hothouses and so on).

According to the measurements provided by the sensors and the pre-programmed parameters (such as the kind of plants and the saltiness of the ground), the controller decides on how far to open the water valve.

The major parameters that determine the irrigation process are:

- Type of growth;
- Status of the growth (height, depth of roots);
- Leaf coverage;
- Kind of soil and saltiness;
- Water budget (economy or normal irrigation).

Therefore, the input parameters that are used by the system are:

- Soil (ground) humidity;
- Temperature;
- Radiation;
- Wind speed;
- Air humidity;
- Salinity (amount of salt in the ground).

The output parameters are:

- Opening/closing the valves for water and/or fertilizer and adjusting their amounts in combination;
- Turning energy systems on/off (lights, heating, ventilation);
- Opening/closing walls and roofs of hothouses [7].

DESIGN OF A FUZZY IRRIGATION CONTROLLER

Figure 1 depicts the block diagram of the controller embedded in the system model. As can be seen, the controller is operated in four interrelated stages.

- **Desired soil moisture:** This block shows the set point of soil moisture that plant can grow up properly.
- **The input variables of soil model:** In this stage some variables represent influence on the rate of soil evaporation such as: Temperature, air humidity, wind speed, radiation.
- **The soil evaporation model stage.** This converts the water flow rate, temperature, air humidity, wind speed and radiation to the actual soil moisture
- **The control stage:** In this stage the desired soil moisture is compared with the measured soil moisture following the comparison, a dynamic decision is made regarding the amount of water to be added to the soil.

In continuation any of four stages will consider that how modeling.

Desired soil moisture: At first according to the kind of plant and type of growth extract amount of water that is necessary for growth and then with consideration of

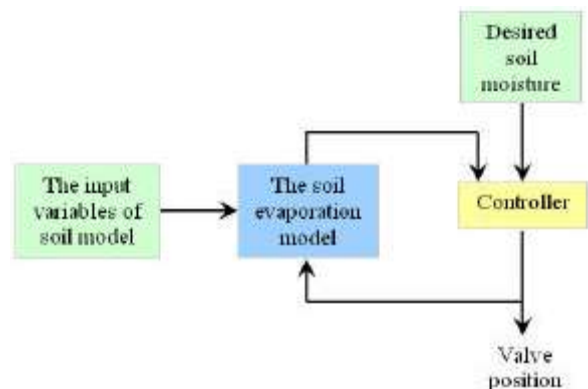

Fig. 1: Irrigation controller block diagram and system model

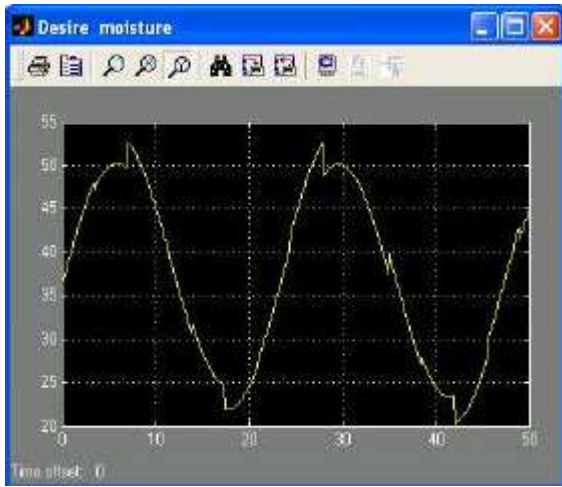

Fig. 2: Desired soil moisture-graphical presentation

kind of soil calculate desired soil moisture that it's different for any kind of plant, type of growth and kind of soil. An assumed graph of desired soil moisture is shown in Fig. 2.

The input variables of soil model: In addition to the amount of water to be added to the soil, four effective factors as: temperature, air humidity, wind speed and radiation influence on the soil evaporation. The input variables were defined as follows:

Temperature: This variable should be defined as a continuous signal (normally as a sine wave which simulated the day and night temperature changes), but my show sharp changes in special places like deserts and so on therefore:

- A sine wave with amplitude of 5 °C;
- A frequency of 0.2618 rad/h. This frequency is measured according to a time period of 24 h: $0.2168 \text{ rad/h} = 2\pi/T = 2\pi/24$.
- A constant bias(offset) of 30 °C;

This stimulus generates a wave which at its maximum can reach 35°C (midday) and at its minimum can reach +25°C (midnight). In this way, the temperature on any given day can be simulated by changing the bias that is attached to the variable. This diversion is obtained by uniform number generation (Light red graph in Fig. 3).

The Air humidity variable:

- A sine wave with amplitude of 10%;
- Bias of 60% (constant);
- A frequency of 0.2618 rad/h (blow graph in Fig. 3).

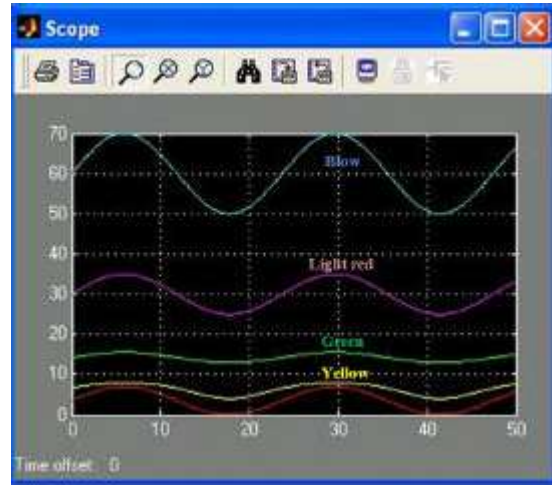

Fig. 3: The input variables of soil model-graphical presentation

The wind speed variable:

- A sine wave with amplitude of 1 Km/h;
- Bias of 3.5 Km/h (constant);
- A frequency of 0.2618 rad/h (yellow graph in Fig. 3).

Radiation: We can simulate radiation changes like before variables but my compiled software in MATLAB has ability to model the radiation with using the geographical equations that explain in next section. (Green graph in Fig. 3).

The soil evaporation model [8, 9]: The FAO Penman-Monteith method is recommended as the sole ETo method for determining reference evapotranspiration. The modified Penman method was considered to offer the best results with minimum possible error in relation to a living grass reference crop. It was expected that the pan method would give acceptable estimates, depending on the location of the pan. The radiation method was suggested for areas where available climatic data include measured air temperature and sunshine, cloudiness or radiation, but not measured wind speed and air humidity.

The FAO Penman-Monteith method to estimate ETo is:

$$ET_o = \frac{0.408\Delta(R_n - G) + \gamma \frac{900}{T + 273} u_2 (e_s - e_a)}{\Delta + \gamma(1 + 0.34u_2)} \quad (1)$$

$$\Delta = \frac{4098 \left[0.6108 \exp\left(\frac{17.27T}{T + 273.3}\right) \right]}{(T + 273.3)^2} \quad (2)$$

$$? = \frac{C_p P}{e^o} = 0.665 \times 10^{-3} P$$

$$P = 101.3 \left(\frac{293 - 0.0065 z}{293} \right)^{5.62} \quad (4)$$

$$e^o(T) = 0.6108 \exp \left[\frac{17.27T}{T + 273.3} \right] \quad (5)$$

Where:

- ETO = Reference evapotranspiration [mm day-1],
- Rn = Net radiation at the crop surface [MJ m-2 day-1],
- G = Soil heat flux density [MJ m-2 day-1],
- T = Mean daily air temperature at 2 m height [°C],
- u2 = Wind speed at 2 m height [m s-1],
- es = Saturation vapour pressure [kPa],
- ea = Actual vapour pressure [kPa],
- es-ea = Saturation vapour pressure deficit [kPa],
- Δ = Slope vapour pressure curve [kPa °C-1],
- γ = Psychrometric constant [kPa °C-1].
- P = Atmospheric pressure [kPa],
- z = Elevation above sea level [m],
- e°(T) = Saturation vapour pressure at the air temperature T [kPa],
- λ = Latent heat of vaporization, 2.45 [MJ kg-1],
- Cp = Specific heat at constant pressure, 1.013 10-3 [MJ kg-1 °C-1],

ε = Ratio molecular weight of water vapour/dry air = 0.622.

The control stage: The control stage interfaces the *desired* soil moisture and the *measured* soil moisture (from the “soil” stage). This stage is intended to keep the actual soil moisture as close as possible to the desired moisture. Its output is the valve control value, which represents the amount of water that should be added to the soil continuously in order to maintain a minimal deviation. The block diagram of the fuzzy controller is shown in Fig. 4.

As can be seen from this figure, the controller has only one input signal (the difference between the desired and the actual soil moisture values) and one output parameter (the valve control). This makes the system very simple and straightforward. The input values are defined in the range [100, 100] and the output values are defined in the range [0, 100]. By doing so, the controller can specify the valve operation in the desired range.

The rules for the controller are very simple. There are only five rules (one rule per input variable). These rules are presented in Fig. 5.

The block diagram of the on/off controller with hysteresis and without it is shown in Fig. 6. In simple on/off controller the valve is opening when desired soil moisture is more than measured soil moisture but in on/off controller that equipped to hysteresis the valve is opening when desired soil moisture is more than measured soil moisture at least of the hysteresis value.

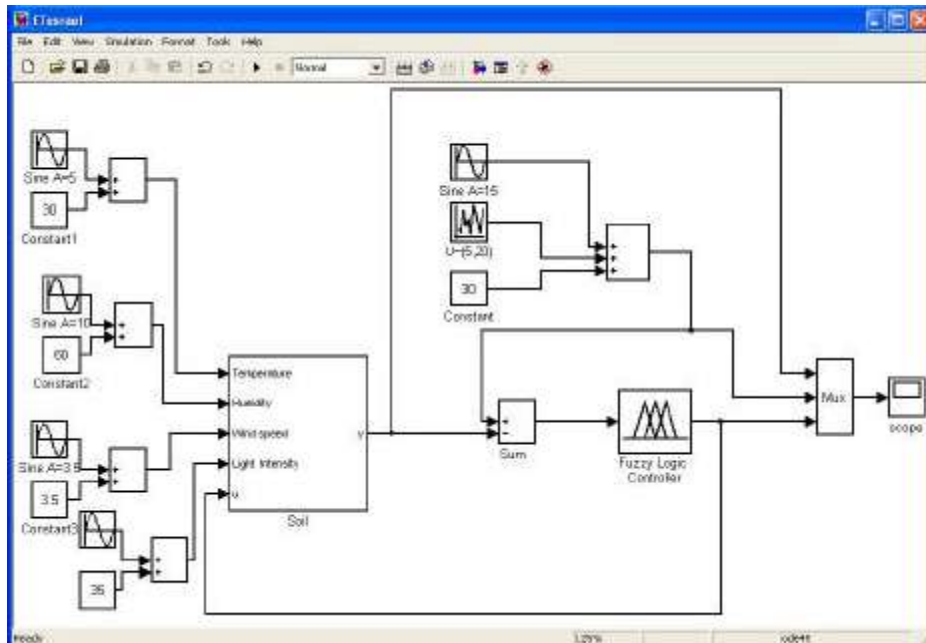

Fig. 4: Diagram of the fuzzy controller system with the soil model

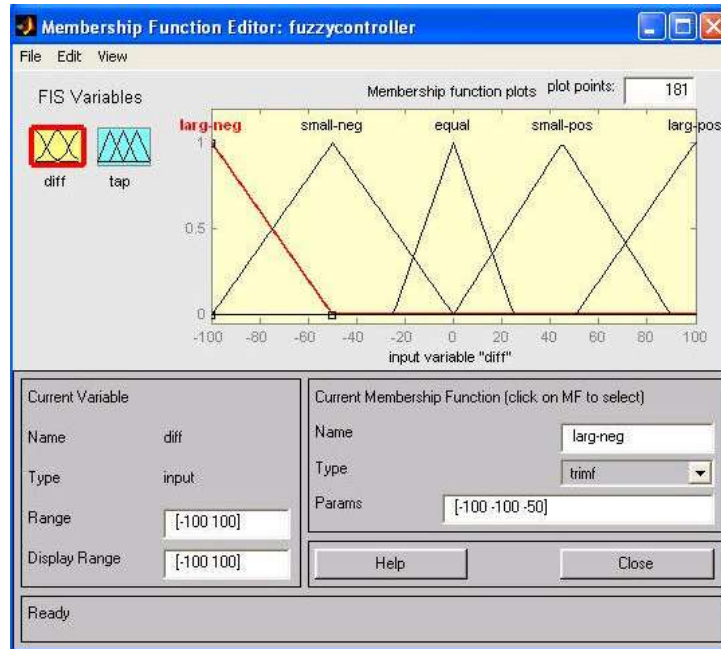

Fig. 5: Fuzzy variable "the difference between the desired and actual soil moisture values"

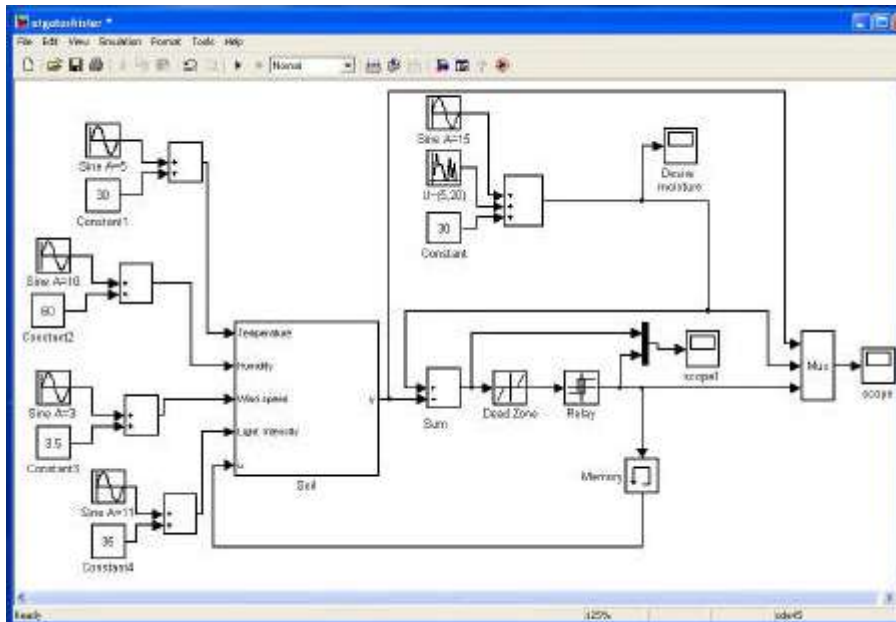

Fig. 6: Diagram of the on/off controller system with hysteresis and without it

SIMULATION RESULTS (BEHAVIOR OF OUTPUT)

Figure 7-10 shows the graphical representation of the simulation results. The legend is as follows:

- Light red signal -desired soil moisture;
- Yellow signal -actual soil moisture;

- Blue signal -valve output (the output of the system).

There are several very important facts that can be extracted from Fig. 10-13.

1. In on/off controller system, actual soil moisture tracks desired one but there are continuous oscillations around the desired values in actual soil

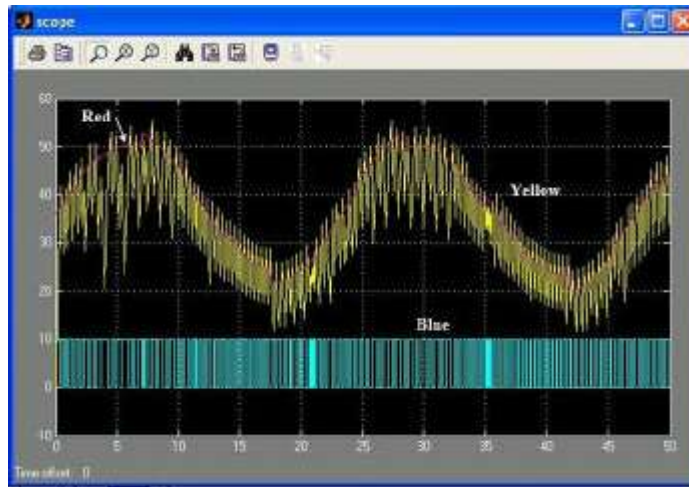

Fig. 7: Simulation results of on/off controller system with ± 4 hysteresis value

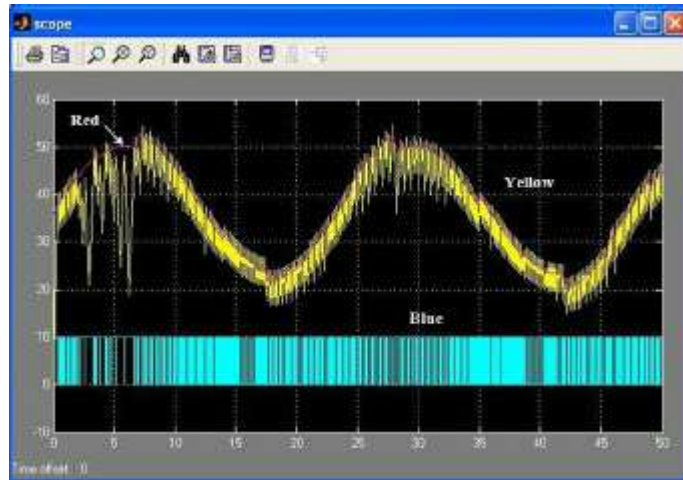

Fig. 8: Simulation results of on/off controller system with ± 2 hysteresis value

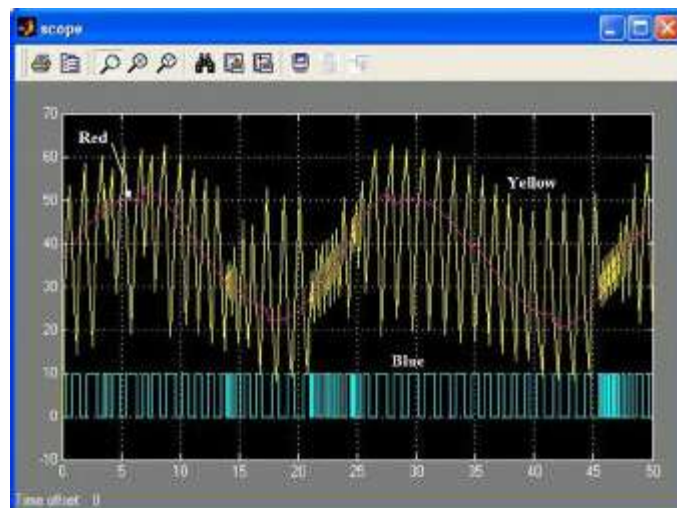

Fig. 9: Simulation results of on/off controller system without hysteresis

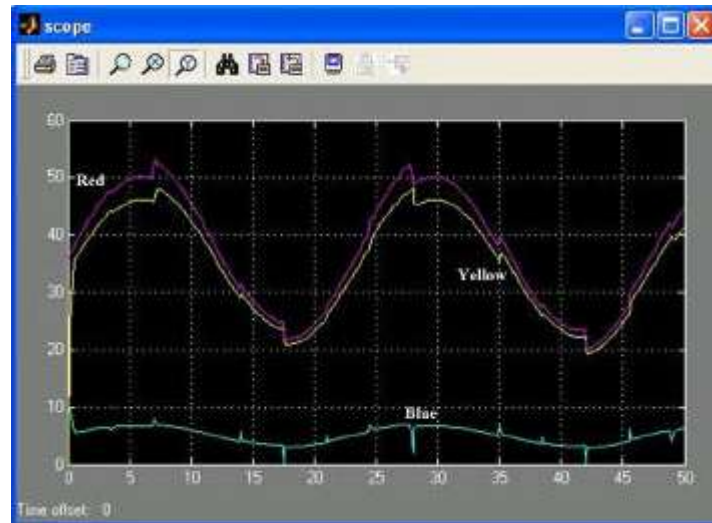

Fig. 10: Simulation results of fuzzy controller system

moisture in other words system isn't stable completely.

2. In on/off controller system with hysteresis, increase oscillations of actual soil moisture, the on/off of valve, rate of amortization and consumption of energy when hysteresis value decrease.
3. In on/off controller system without hysteresis, oscillations of actual soil moisture, the on/off of valve. And consumption of energy decreases relative to one with hysteresis instead the wastage of water and water stress in soil and plant increase.
4. The actual soil moisture tracks the desired one without any oscillation in fuzzy controller system
5. The difference between them (the "error") is reasonable and it is quite steady (around 2-3%). This shows that the irrigation controller is stable.
6. In fuzzy controller system the on/off of valve and consumption of energy is less than on/off controller system and so is prevented of water stress in soil and plant.
7. Each of three controller system, the source-generation model allows the user a wide variety of climate combinations; therefore, the controller can operate in any circumstances.
8. The main target -to design a cheap and reliable irrigation controller -has been achieved in fuzzy controller system.

CONCLUSIONS

This paper has compared three systems equipped to on/off with hysteresis, simple on/off and fuzzy controller with each other. First, it explained the general architecture and its components. Then some

examples showed that the system operates within the proper range and is stable. Consequently fuzzy controller system had more ability as compared with another system. It is important to note that such system can save a lot of water and is very cheap to implement. The fuzzy rules are simple (as shown in Fig. 8), therefore making the system attractive to use by all types of agriculturists.

REFERENCES

1. Evans, R., R.E. Sneed and D.K. Cassel, 2006. Irrigation scheduling to improve water and energy use efficiencies, North Carolina Cooperative extension Service (AG 452-4).
2. Reuter, D.C. and R.S. Everett, 2000. Control theory and applications: Neural-fuzzy controller for lawn irrigation.
3. Zazueta, F.S., A.G. Smajstrla and G.A. Clark, 1994. Irrigation system controllers. Institute of Food and Agriculture Science, University of Florida (AGE-32).
4. Burman, R. and L.O. Pochop, 2004. Evaporation evapotranspiration and climatic data. Elsevier, Amsterdam.
5. Or, D., 2005. Soil water sensors placement and interpretation for drip irrigation management in heterogeneous soils. In: Proceeding of 5th International Microirrigation Congress, pp: 214-222.
6. Ioslovich, I., P. Gutman and I. Seginer, 2006. A non linear optimal greenhouse control problem with heating and ventilation. Optimal Control Applications and Methods, 17: 157-169.

7. Bahat, M., G. Inbar, O. Yaniv and M. Schneider, 2000. A fuzzy irrigation controller system. *Engineering Applications of Artificial Intelligence*, 13: 137-145.
8. Richard, G.A., S.P. Luis, R. Dirk and S. Martin, 2006. *FAO Irrigation and Drainage Paper, No. 56: Crop Evapotranspiration*.
9. Alizadeh, A., 2006. *Soil water-plant relation ship*, Astane Ghodse Razavi.