

Design of Transformer-Less Sliding Mode Controlled Resonant DC-DC Converter

D. Yalini Vinnarasi and N. Soundiraraj

Department of EEE, PSNA College of Engg and Tech., Dindigul-624 622, Tamil Nadu, India

Abstract: Renewable energy generation interfaces are widely used for their clean energy; these renewable interfaces require a power electronic interface to condition their power as the sources are affected by environmental conditions. This paper presents a Transformer-less sliding mode controlled resonant dc-dc converter with adjustable voltage quadrupler. Current distortion is reduced by using simple sliding mode control. And it is necessary to employ a transformer for boosting which results in higher cost and higher input surge current to lower the maximum output power. So in sequence to lower the structure price, as well as to boost up the structure efficiency, a without transformer is a suitable resolution. It is a switched capacitor based converter. So it developed the transformation efficiency for obtain the higher transformation ratio. Additionally the converter is applicable for high extensive voltage applications for being adjustable voltage quadrupler transformation capacity. The proposed transformer-less resonant dc-dc converter has been examined in the sliding mode control, which is being simulated on a 25/400w output with PLEXIM software technique.

Key words: Resonant converter • Adjustable voltage quadrupler • Sliding mode control • PLEXIM tool

INTRODUCTION

Resonant converters have become very popular and it is widely used in many applications are as follows. There are wireless energy transfer system [1], battery charger [2], electric vehicles [3, 4] and etc. By the reason of larger symphonic voltages are strained by resonant network in the converter. Wireless energy transfer system has Eigen modes with more LC resonators. So this magnetic field is uncertainly connected. And it is analyzed in the matrix calculus [1]. Resonant converter has been categorized into many types of resonant tank. There are LC-RC [5, 6], LCC-RC [7, 8], CLL-RC [9], LLC-RC [10]. Above these resonant converter tanks the LLC-RC is the best solution [10]. LLC converter has operating point which is indeed of the proximity of resonant frequency. So it minimizes the dispensing current and turning off current within the magnetizing inductor and MOSFETs. According to the characteristics the resonant converter can be categorized as series resonant converter, parallel resonant converter and series parallel resonant converter. By the reason of the series resonant dc-dc converter has output voltage, which is being restrained through

changes of switching number. Based on the lithium iron battery impedance deviation, the switches number was saliently high and remarkably the switching failure is increased.

Among these RC topologies has some disadvantages are as following.

- 1) It has high cost.
 - ▶ Because transformer circuits are included.
- 2) It has high losses.
 - ▶ Because more components are required.
- 3) In control techniques wise Low bandwidth efficiency,

So we can overcome above this problem to move the transformer-less resonant converter which is being more than as possible.

Here some advantages are as following.

- 1) It has high efficiency.
- 2) It has low cost,
 - ▶ Because which is not used in transformer in this circuit.

- 3) In this system has less component required as compared to existing system.
- 4) It has implemented by sliding mode control techniques.
 - ▶ Because dynamic response will be fast as compared phase shift key.
- 5) It has been simulated by using PLEXIM software tool.
 - ▶ Because this techniques where high speed up simulation as compared to MATLAB simulation.

Proposed Topologies

Resonant Adjustable Voltage Quadrupler: For suitable cite the two phase interleaved boost converter circuit as shown in Figure. 2(a). The proposed topologies of transformer-less RAVQ as shown in fig. 2(b). From this fig 2(b) is basically obtained from a two phase interleaved boost converter and it has added extra diodes and capacitors. Hence throughout the energy shift period partial inductor reserved energy is supplied in one capacitor and same as partial inductor is supplied with other capacitor. So this reserved energy is altered. In spite of the designed output voltage is double times increased as compared than the existing one that is voltage doublers circuits.

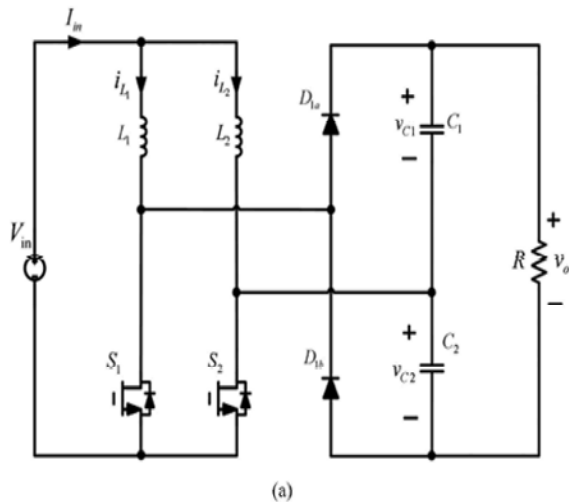
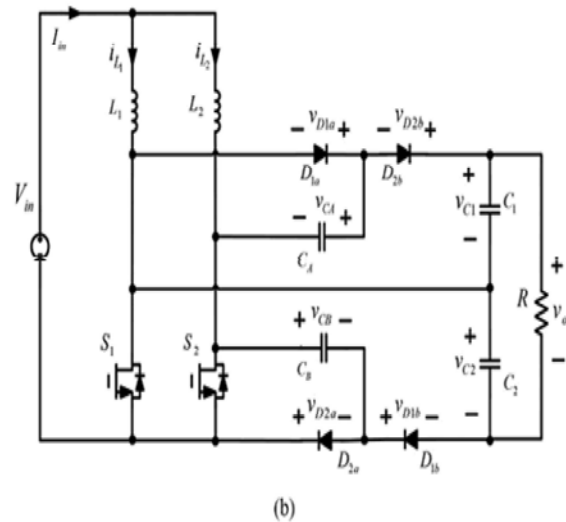

Fig. 2(a): Configuration of two-phase interleaved boost converter

As well as an each active switches and diodes are explained under later. The proposed converter has automatic current shift characteristics. So it will able to shift the current in same without any multiple control methods. The operating principle has made of some assumptions and dc converter have own the disadvantages of the continuation of oscillating output

interval. From this proposed converter, it will get the high voltage gain for grid connected inverters at converter stages. According to the characteristics, the duty cycle will be change for shown in below; if the duty cycle is larger than the 0.5 then it is called continuous conduction mode. So this conduction mode is made only for this steady state analysis. If the duty cycle is lower than 0.5, then it is called discontinuous conduction mode. From this conduction mode case does not possible to shifting the energy shift period for output capacitors, blocking capacitors and load. Then it will not to get the higher voltage gain while the duty cycle is lower than the 0.5. From this figure 2(b), the proposed converter topology has been categorized as four operating stages are shown in below.



The Proposed Converter

Operating Stages: Here the circuit of proposed topology is introduced and its working principle is explained with help of transformer-less resonant adjustable voltage quadrupler with four operating stages. There are stage 1, stage2, satge3, stage4. The proposed converter circuit has been made of some parameters are as follows. Such as two active switches, four active diodes, capacitors and resistive load.

Stage 1: At t_0 to t_1 , the switches S_1 and S_2 are conducting and diodes D_{1a} , D_{1b} , D_{2a} and D_{2b} are not conducting. The stage 1 equivalent circuit as shown in Fig. 4(a). The energy is mainly stored in inductor L_1 and L_2 . This stored energy is increased as iL_1 and iL_2 which is respectively. Capacitor voltages V_{CA} and V_{CB} are clamped by the diode voltage as D_{1a} and D_{2a} . Both the subtraction

of capacitor voltages V_{C2} minus V_{CB} and v_{c1} minus V_{CA} which is clamped by the diode voltage as D_{2a} and D_{2b} , the stage 1 characteristics equations are as shown in below.

$$L_1 \frac{diL_1}{dt} = V_{in} \quad (1)$$

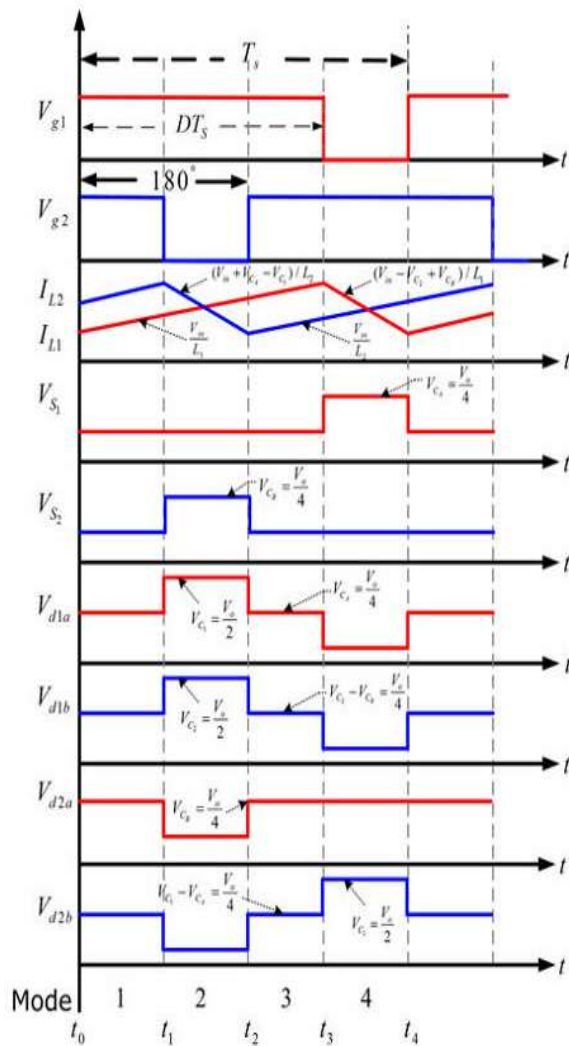

Fig. 3: Operating waveform

$$L_2 \frac{diL_2}{dt} = V_{in} \quad (2)$$

$$C_A \frac{dV_{CA}}{dt} = 0 \quad (3)$$

$$C_B \frac{dV_{CB}}{dt} = 0 \quad (4)$$

Stage 2: At t_2 to t_3 , the switches s_1 and s_2 are conducting. This stage is observed Fig 4(b). So the related circuit as shown in below. The energy is reserved in inductor L_2 and capacitor C_A . This reserved energy is discharged to the output capacitor C_1 and load and again this energy is reserved in C_A . The addition of V_{CB} plus V_{CA} which is equal to V_{C1} .

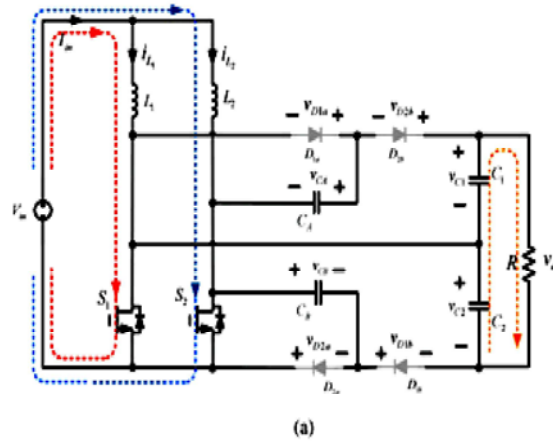
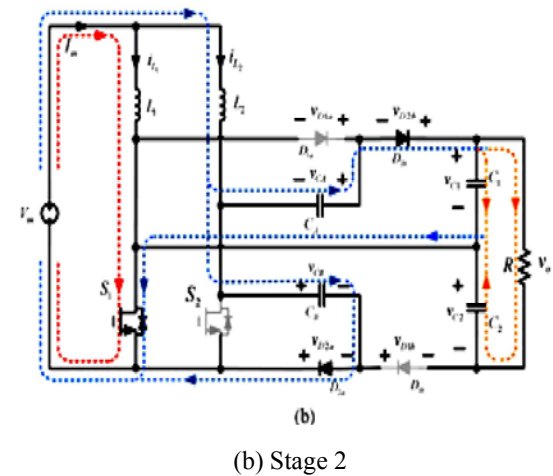

Fig 4 (a) Stage 1 & Stage 3



(b) Stage 2

Then iL_1 is continuously increased and iL_2 is linearly decreased.

$$C_A \frac{dV_{CA}}{dt} = -i_{CB} - i_{L2} \quad (5)$$

$$C_A \frac{dV_{CA}}{dt} = -i_{CB} - i_{L2} \quad (6)$$

$$C_1 \frac{dV_{C1}}{dt} = -i_{C_A} - \frac{V_{C1} + V_{C2}}{R} \quad (7)$$

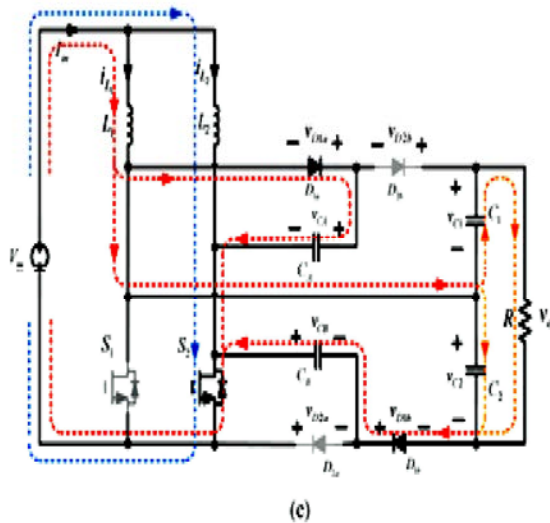

(c) Stage 4

$$C_2 \frac{dV_{C2}}{dt} = -\frac{V_{C1} + V_{C2}}{R} \quad (8)$$

$$C_1 \frac{dV_{C1}}{dt} = -i_{C_B} - \frac{V_{C1} + V_{C2}}{R} \quad (9)$$

Stage 3: This stage operation is similar to the stage 1 as shown in Fig 4(a)

Stage 4: At t_3 to t_4 , the switch s_2 is conducting and the switch s_1 is not conducting and the remaining diodes D_{1a} and D_{1b} are charging. This stage 4 equivalent circuit as shown in fig 4(c). The reserved energy is discharged in inductor L_1 and capacitor C_B . This reserved energy is discharged to the output capacitor C_2 and load L_1 and again this energy is reserved in C_A . The addition of V_{CB} plus V_{CA} which is equal to V_{c2} . Then i_{L2} is continuously increased and i_{L1} is linearly decreased.

$$L_2 \frac{di_{L2}}{dt} = V_{in} \quad (10)$$

$$C_A \frac{dV_{C_A}}{dt} = i_{C_B} + i_{L1} \quad (11)$$

$$C_1 \frac{dV_{C1}}{dt} = -\frac{(V_{C1} + V_{C2})}{R} \quad (12)$$

From these operating stages, the proposed converter can be easy to implement; and if it is low force on a any active switches and diodes, then only it can share the same current and to get the higher voltage transfer gain.

Analysis and Characteristics

Steady State Analysis: The steady state analysis of the proposed converter has been made in some assumptions are as follows;(1) voltage gain method, (2) uniform current sharing method

Voltage Gain: To obtain the high voltage gain without voltage forces on any active switches and diodes, thus it can follow these equations;

$$V_{in}D + (V_{in} - V_{CA})(1 - D) = 0 \quad (13)$$

$$V_{in}D + (V_{in} - V_{CB})(1 - D) = 0 \quad (14)$$

Uniform Current Sharing Method: When the duty cycle is larger than 0.5, then it can share the same current in the resonant converter. This method can follow this equations are as shown in below;

$$I_{L1} = I_{L2} = \frac{2}{1 - D} + \frac{DC_1}{(1 - D)C_2} I_o \quad (15)$$

Implementation of Proposed Control Techniques

Sliding Mode Control: Sliding mode control is one of the control systems. It is a particular place which extracts the mathematical solution in many cases. It is a nonlinear control method for adapt the dynamics of the control system. It has a volatile structure. This paper has a drawback of current distortion, which is reduced by using sliding mode control. It has some benefits are as follows;(1).It has a better dynamic response,(2).It has a Better tracking efficiency,(3).It has an invariance system.(4).It has a lower disturbance.

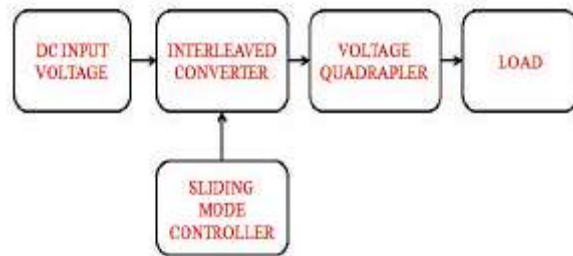
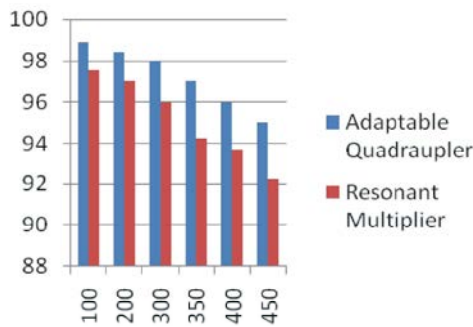

Fig. 5: Control block diagram

Performance Comparison



Comparison Graph of Multiplier v, Quadrupler

This figure shows that the load V_s efficiency graph, which indicates that the proposed one (adjustable voltage quadrupler) is better than the existing one (voltage multiplier).

Simulation Results: The circuit was designed and explored in PLEXIM tool according to the design procedure, by the reason of high speed execution process. The proposed structure is simulated for transformer-less sliding mode controlled resonant dc-dc converter with adjustable voltage quadruple using PLEXIM tool as shown in below. This tool which carried out these waveforms; such as diode current waveform, diode voltage waveform and efficiency waveform.

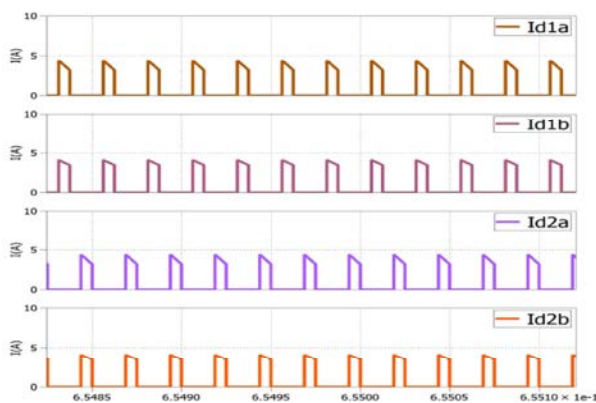

Fig. 6: Simulation result of diode current

This figure shows that the Diode voltage waveform, which indicates that the maximum voltage cross the diodes V_{D1a} , V_{D1b} and V_{D2b} .

This figure shows that the Diode voltage waveform, which indicates that the maximum voltage cross the diodes V_{D1a} , V_{D1b} and V_{D2b} .

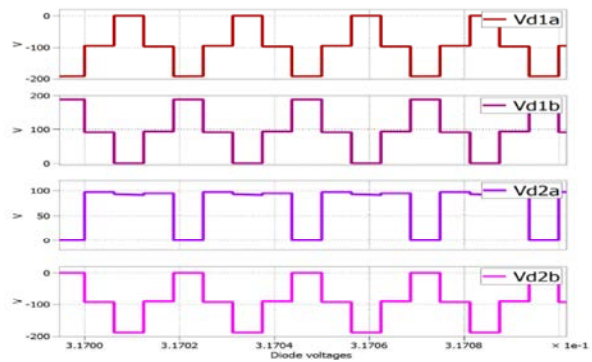

Fig. 7: Simulation result of diode voltage

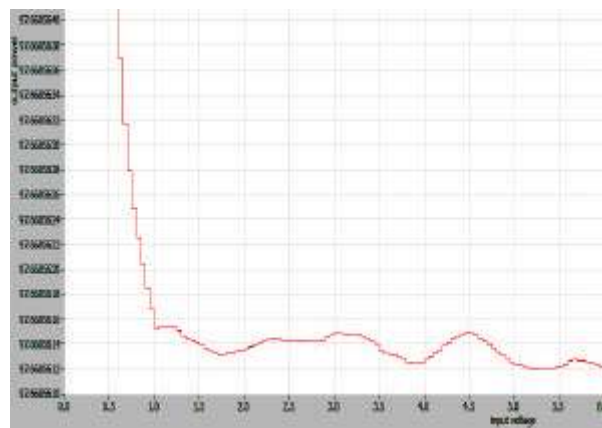

Fig. 10: Simulation result of output efficiency V_s input voltage

This figure shows that the output efficiency is 97.66 as per the given input voltage is 25 volts.

CONCLUSION

The proposed transformer-less resonant converter was analyzed in adjustable voltage quadrupler by using the sliding mode control technique. This control is used to reduce the current distortion in this converter. This design was constructed in lower cost and lower voltage stress a without transformer dc-dc resonant converter is more possible solution as here. Because it is used in grid connected inverters at converter stages (i.e.) micro grid inverter and low input dc applications. By the reason of the voltage step up conversion; the adjustable voltage quadrupler is basically extracted from two phase interleaved boost converter. Finally a transformer-less sliding mode controlled resonant dc-dc converter has been examined in the sliding mode control technique for a 400w output rating with the 25v input (i.e.) 25v/400w as

being simulated using PLXIM software technique. It can operate with a better efficiency over a wide range of application without any stresses and complex design.

REFERENCES

1. Karaca, O., F. Kappeler, D. Waldau, R.M. Kennel and J. Rackles, 2014. Eigenmode analysis of a multiresonant wireless energy transfer system, *IEEE Trans. Ind. Electron.*, 61(8): 4134-4141.
2. Wang, H., S. Dusmez and A. Khaligh, 2014. Maximum Efficiency Point Tracking for LLC-based PEV Chargers Through Variable DC Link Control, *IEEE Trans. Ind. Electron.*, 61(11): 6041-6049.
3. Ryu, S.H., D.H. Kim, M.J. Kim, J.S. Kim and B.K. Lee, 2014. Adjustable frequency-duty-cycle hybrid control strategy for full-bridge series resonant converters in electric vehicle chargers, *IEEE Trans. Ind. Electron.*, 61(10): 5354-5362.
4. Zhu, Q., L. Wang and C. Liao, 2014. Compensate capacitor optimization for kilowatt-level magnetically resonant wireless charging system, *IEEE Trans. Ind. Electron.*, 61(12): 6758-6768.
5. Jang, Y., M.M. Jovanovic, J.M. Ruiz and G. Liu, 2015. Series-resonant converter with reduced-frequency-range control, in *Proc. IEEE APEC*, 2015, pp: 1453-1460.
6. Molla-Ahmadian, H., F. Tahami, A. Karimpour and N. Pariz, 2015. Hybrid control of DC-DC series-resonant converters: the direct piecewise affine approach, *IEEE Trans. Power Electron.*, 30(3): 1714-1723.
7. Soeiro, T.B., J. Muhlethaler, J. Linner, P. Ranstad and J.W. Kolar, 2013. Automated design of a high-power high-frequency LCC resonant converter for electrostatic precipitators, *IEEE Trans. Ind. Electron.*, 60(11): 4805-4819.
8. Yang, R., H. Ding, Y. Xu, L. Yao and Y. Xiang, 2014. An analytical steady-state model of LCC type series-parallel resonant converter with capacitive output filter, *IEEE Trans. Power Electron.*, 29(1): 328-338.
9. Asa, E., K. Colak and D. Czarkowski, 2014. Analysis of a novel interleaved CLL resonant converter for EV battery charger applications, in *Proc. IEEE ECCE*, pp: 2031-2036.
10. Fu, D., S. Wang, P. Kong, F.C. Lee and D. Huang, 2013. Novel techniques to suppress the common-mode EMI noise caused by transformer parasitic capacitances in DC-DC converters, *IEEE Trans. Ind. Electron.*, 60(11): 4968-4977.