

A Novel Approach for Enhancement of Power Quality by Reduction of Total Harmonic Distortion in Three Phase Four Wire System

K.S.S. Prasad

Department of EEE,
Bharath University, Chennai, India

Abstract: This paper presents a fuzzy logic, PI, average current controlled shunt active power filter used to compensate for harmonic distortion in three-phase four-wire systems. The shunt active filter employs a simple method for the calculation of the reference compensation current based on Fast Fourier Transform. The presented Shunt Active Power filter is able to operate in balanced, unbalanced and Variable load conditions. Classic filters may not have satisfactory performance in fast varying conditions. But auto tuned active power filter gives better results for harmonic minimization, reactive power compensation and power factor improvement. The proposed auto tuned shunt active filter maintains the THD well within IEEE-519 standards. The proposed methodology is extensively tested for wide range of different Loads with Improved dynamic behavior of shunt active power filter using fuzzy logic, PI controllers. The results are found to be quite satisfactory to mitigate harmonic Distortions, reactive power compensation and power factor improvement.

Key words: Active power filters (APFs) • Harmonics • Hybridfilters • Instantaneous reactive power • Power quality

INTRODUCTION

In recent years, power quality distortion has become serious problem in electrical power systems due to the Increase of nonlinear loads drawing nonsinusoidal currents Active filters have been widely used for harmonic mitigations well as reactive power compensation, load balancing, voltage regulation and voltage flicker compensation In three-phase four-wire systems with nonlinear loads a high level of harmonic currents in both the three line conductors and more significantly in the neutral wire has been enrolled. Unbalanced loads also results in further declination of the Supply quality Various harmonic mitigation techniques have been proposed to reduce the effect of harmonics [1]. These techniques include phase multiplication, passive filters, active power filters (APFs) and harmonic injection. One of the most popular APFs is the shunt active power filter. It is mainly a current source, Connected in parallel with the non-linear loads. Conventionally, a shunt APF is controlled in such a way as to inject harmonic and reactive compensation currents based on calculated reference currents. The injected currents are meant to

cancel the harmonic and reactive currents drawn by the nonlinear loads [2-5]. Recently, fuzzy logic controller has generated a great deal of Interest in various applications and has been introduced in the power electronics field. The advantages of fuzzy logic controllers over the conventional PI controller are that they do not need an accurate mathematical model; they can work with imprecise inputs, can handle nonlinearity and may be more robust than the conventional PI controller. Use of fuzzy logic for minimization of harmonics and improvement of power quality is not a new issue rather various authors have introduced some innovative methodologies using these tools [6-9]. The most important observation from the work reported by various researchers for power quality improvement is the Design of active power filter under 'fixed load' conditions or for loads with slow and small variation. As loads in practical life are mostly variable, there is the need to design an active power filter, which is capable of maintaining the THD well within the IEEE norms, under variable load conditions. Presence of harmonics increase the frequency in the system. As the frequency is directly proportional iron loss. Harmonics increases the losses and causes

heating of distribution transformer and conductors. At variable frequency, malfunction of load occurs, which affects the reliability of the system.

Shunt Active Power Filter: In a modern electrical distribution system, there has been a sudden increase of nonlinear loads, such as power supplies, rectifier equipment, domestic appliances and adjustable speed drives (ASD), etc. As the number of these loads increased, harmonics currents generated by these loads may become very significant. These harmonics can lead to a variety of different power system problems including the distorted voltage waveforms, equipment overheating, malfunction in system protection, excessive neutral currents, light flicker, inaccurate power flow metering, etc. They also reduce efficiency by drawing reactive current component from the distribution network [8]. In order to overcome these problems, active power filters (APFs) have been developed. The voltage-source inverter (VSI)-based shunt active power filter has been used in recent years and recognized as a viable solution the control scheme, in which the required compensating currents are determined by sensing line currents only, which is simple and easy to implement. The scheme uses a conventional proportional plus integral (PI) controller for the generation of a reference current.

Basic Compensation Principal: APF. A current controlled voltage source inverter with necessary passive components is used as an APF as shown in fig 1. It is controlled to draw/supply a compensated current from/to the utility, such that it eliminates reactive and harmonic currents of the non-linear load. Thus, the resulting total current drawn from the ac mains is sinusoidal. Ideally, the APF needs to generate just enough reactive and harmonic current to compensate the nonlinear loads in the line.

Fuzzy Logic Current Controller: The desired switching signals for the filter inverter circuit are determined according to the error in the filter current using Fuzzy logic controller. The parameters for the fuzzy logic current controller used in this paper are as follows. The design uses centrifugal defuzzification method. There are two inputs; error and its derivative and one output, which is the command signal to the PWM of the filter inverter. The two input uses Gaussian membership functions while the output use triangle membership function. The Fig. 2, Fig.3 and Fig.4 represent the test system simulation with balanced, unbalanced and variable loads.

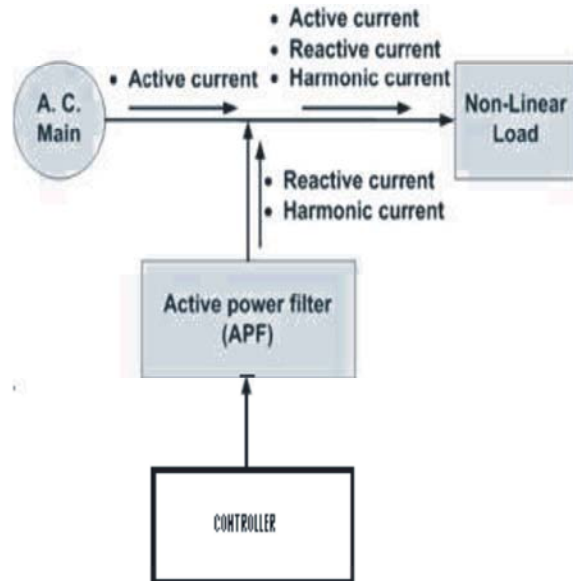

Fig 1: Connection of shunt active filter with nonlinear load

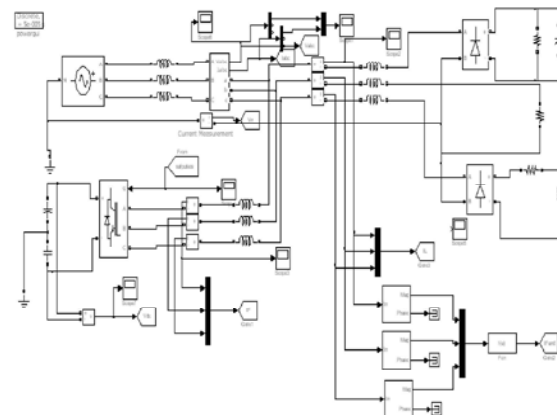

Fig 2: The test system simulation with unbalanced nonlinear load

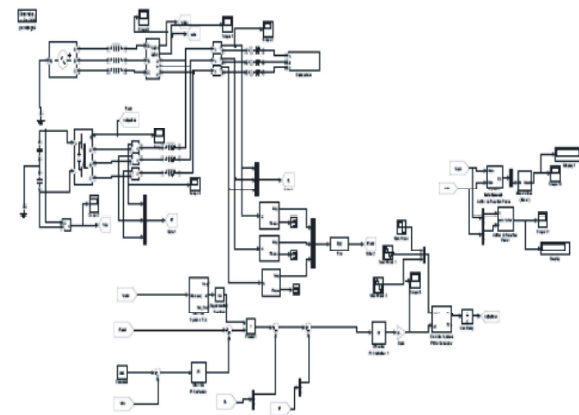

Fig 3: The test system simulation with variable or dynamic nonlinear load

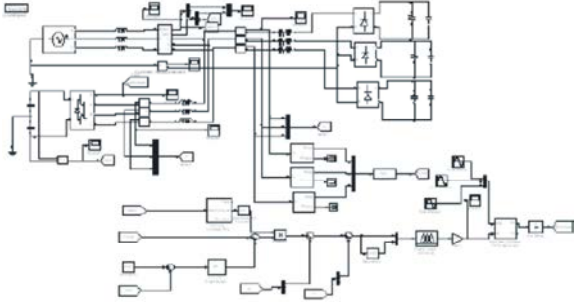

Fig 4: The test system simulation with balanced nonlinear load

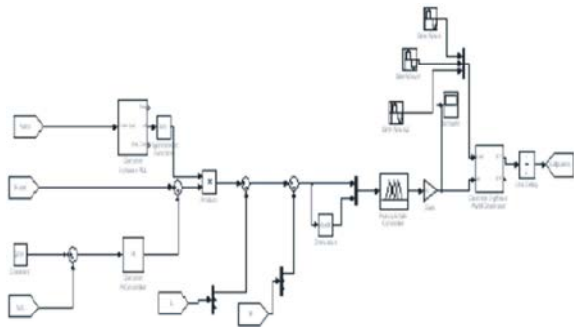

Fig 5: Control strategy for shunt APF with fuzzy

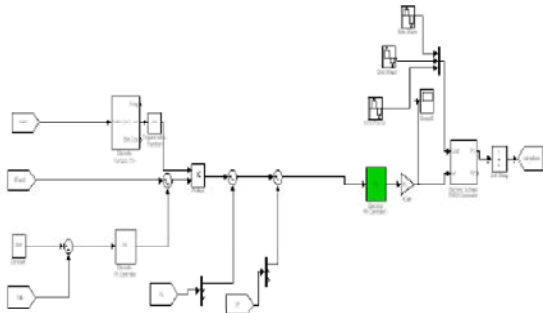

Fig.6. Control strategy for shunt APF with PI controller

Proposed PI control scheme: The active power filter compensation system and the schematic diagram of the PI control scheme, respectively. In order to implement the control algorithm of a shunt active power filter, the DC capacitor voltage (V_{dc}) is sensed and compared with the reference value (V_{dcref}). The Input of PI controller is the value of Error, $e = V_{dcref} - V_{dc}$ and its output, after a limit, is considered as the magnitude of peak reference current I_{ref} . The switching signal for the PWM converter are obtained from comparing the actual source currents (i_{sa}, i_{sb}, i_{sc}) with the reference current templates ($I_{sa}^*, I_{sb}^*, I_{sc}^*$) in a hysteresis current controller. The output pulses are applied to the switching devices of

Fig 7: Simulation results

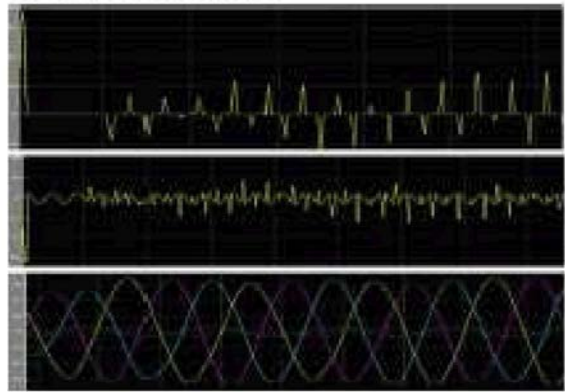

Fig 7(a): Waveforms of load current, filter current, supply current and supply voltage of balanced non linear load using PI controller with respect to time

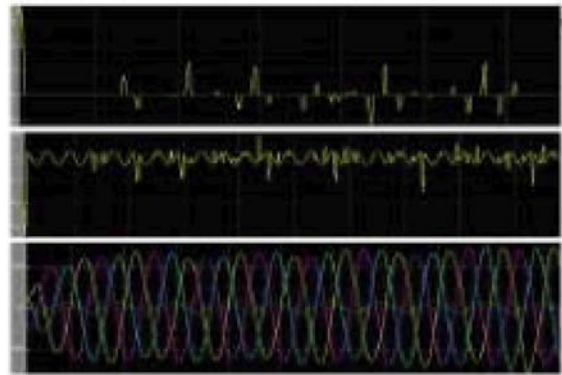

Fig 7(b): Waveforms of load current, filter current, supply current and supply voltage of unbalanced non linear load using PI controller with respect to time.

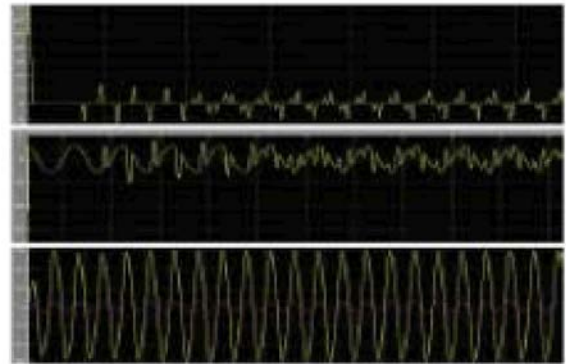

Fig 7(c): Waveforms of load current, filter current, supply current and supply voltage of balanced non linear load using fuzzy controller with respect to time

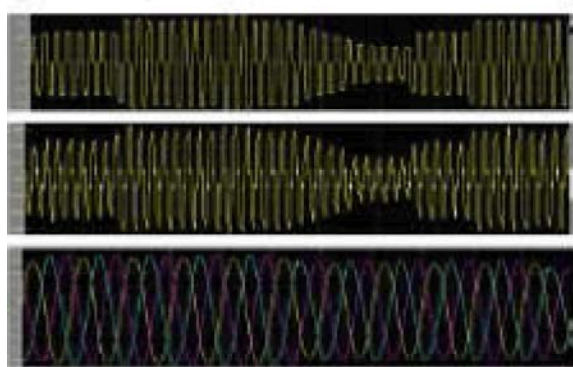

Fig 7(d): Waveforms of load current, filter current, supply current and supply voltage of unbalanced non linear load using PI controller with respect to time

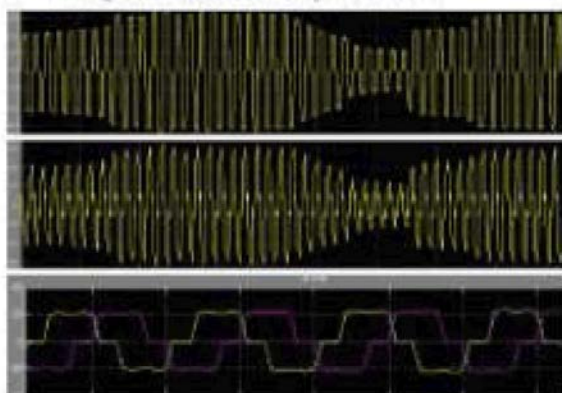

Fig 7(e): Waveforms of load current, filter current, supply current and supply voltage of unbalanced dynamic non linear load using PI controller with respect to time

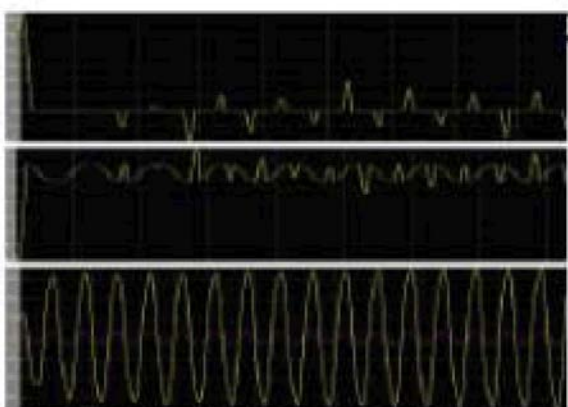

Fig 7(f): Waveforms of load current, filter current, supply current and supply voltage of unbalanced dynamic non linear load using fuzzy controller with respect to time.

the PWM converter. Since coefficients of PI controller, K_p and K_i , are fixed in this model, the performance of active power filter under random load variation conditions is not as well as ‘fixed load’ condition. To overcome this problem and make a robust controller, a fuzzy logic controller (FLC) is designed to tune K_p and K_i on the base of load current value. The following Fig.7 fig. 8 shows FIS editor and FIS file viewer Fuzzy degree of membership for the error and its derivative and the command signal respectively.

Comparison of % Thd, Power Factor and Reactive Compensation Table for Pi, Fuzzy:

Control Scheme →	PI				Fuzzy			
	THD (%)	POWER FACTOR	Reactive Power(Var)		THD	POWER FACTOR	Reactive Power(Var)	
			With Filter	With Out filter			With Filter	With Out filter
Balanced Load	4.9	0.8555	51.12	125.9	2.82	0.972	17.6	125
Unbalanced load	2.84	0.9996	19.38	31.67	2.82	0.9997	33	31.67
Variable load	2.82	0.9993	36.26	52.6	1.56	0.9999	38	51

CONCLUSION

The proposed Shunt Active Filter (SAF) can compensate for balanced, unbalanced and Variable nonlinear load currents. Proposed SAF adapt itself to compensate for variation in non linear currents. Simulation results shown that system limits THD percentage of source current under limits of IEEE- 519 standard (5%). and also observed that Power factor and Reactive power compensation is improved.

REFERENCES

1. Elmitwally, A., S. Abdelkader and M. Elkateb, 2000. Performance evaluation of fuzzy controlled three and four wire shunt active power conditioners IEEE Power Engineering Society Winter Meeting, 3(23/27): 1650-1655.

2. Singh, G. K., 2009. Power system harmonics research: a survey European Transactions on Electrical Power, pp: 151-172.
3. Bose, B.K., 1999. Expert Systems, Fuzzy Logic and Neural Network Application in Power Electronics and Motion Control. Piscataway, NJ: IEEE Press, ch., pp: 11.
4. Dell'Aquila, A. Lecci and V.G. Monopoli, 2002. Fuzzy controlled active filter driven by an innovative current reference for cost reduction, in proc. IEEE Int. symp. Ind. Electron., 3: 26-29-948-952.
5. Singh, B., A. Chandra and K. Al-Haddad, 1999. Computer-aided modeling and simulation of active power filters, *Elect. Mach. Power Syst.*, 27: 1227-1241.
6. Singh, G.K., A.K. Singh and R. Mitra, 2006 A simple fuzzy logic based robust active power filter for harmonics minimization under random load variation *Electr. Power Syst. Res.*
7. Recommended Practices and Requirements for Harmonic Control in Electronic Power Systems, IEEE Standard 519-1992, New York, 1993.
8. Mortazavi, S.S. and R. Kianinezhad, A. Ghasemi Auto Tuned Robust Active Power Filter for Power Quality Improvement under Fast Load Variation.
9. Ahmed, A. Helal, Nahla E. Zakzouk and Yasser G. Desouky, 0000. Fuzzy Logic Controlled Shunt Active Power Filter for Three-phase Four-wire Systems with Balanced and Unbalanced Loads.